

ADIMEC-1600m

Real time, digital 2-Megapixel
monochrome camera for fast machine
vision applications

- 1600 x 1200 pixels with up to 34 progressive images per second
- Full a-synchronous image capture with programmable partial scan
- Small outline & low power consumption
- Unparalleled image quality



Sales Europe & Far East
ADIMEC Europe
The Netherlands
Phone: (+31) 40-2353920
Fax: (+31) 40-2353925
E-mail: saleseu@adimec.com

Sales North America
ADIMEC USA
Phone: (+1) 781-279-0770
Fax: (+1) 781-279-0571
E-mail: salesus@adimec.com

Sales Japan
ADIMEC Japan
Phone: (+81) 3-5968-8377
Fax: (+81) 3-5968-8388
E-mail: salesjp@adimec.com

Member of a fully compatible product family sharing a common mechanical, optical, hardware and software interface

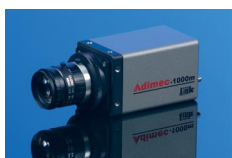

Adimec-1000m
1004x1004@50 fps



Adimec-2000m
1920x1080@32fps



Adimec-4000m
2048x2048@16fps



Adimec-4020m
2048x2048@16fps

ADIMEC-1600m



Adimec is a prominent international supplier of high performance video cameras for use in machine vision, medical and military applications. Adimec targets OEM companies with a leading position in their market that consider performance and reliability of the product and the supplier to be critically important. Adimec has over ten years experience translating demanding customer requirements into innovative, reliable and high performance camera products.

Our mission is to provide superior camera products to companies around the world that view image quality and product reliability as essential to their applications.



FEATURES

- 1600 x 1200, 7.4 um square pixels
- Interline CCD with microlenses with high Blue and NIR response
- Very stable and accurate sensor mounting
- High frame rate
- Excellent channel matching characteristics
- Continuous or asynchronous operation
- Partial scan
- Defect pixel correction
- Built-in test signal generator
- Camera Link Interface
- Small outline & low power consumption
- High product reliability through rugged design
- Option programmable digital fine gain and/or 12 bit output resolution

APPLICATIONS

- Semiconductor inspection
- Electronics manufacturing
- 2D & 3D metrology

SPECIFICATIONS

Resolution, pixel size	1600 x 1200, 7.4 um square pixels
Frame rate @ full resolution	Adimec-1600m/S: 18 fps via single tap output Adimec-1600m/D: 34 fps via dual tap output
Partial scan	147 fps at 128 x 1600 (max speed at min. size)
Sensitivity @ 33 ms	1x Gain 4.5 Lux
100% video	8x Gain 0.56 Lux
Spectral Response	400 nm 46%, 480 nm 55%, 700 nm 24%
Dynamic range	> 60 dB
Gain range	1, 2, 4 or 8 times, Optional DFG (1 to 8x in steps of 0.01)
MTF	50% contrast @ 67 lp/mm (limiting resolution)
Power input range, dissipation	< 6 W @10.5 to 14 Vdc input
Data format	CameraLink, (single/dual channel, Base configuration@CameraLink spec 1.0 8, 10, (optional 12 bit) , 40 MHz)
Lens mount	Adjustable C- mount, other mount on requests
Size	52.5 mm x 52.5 mm x 79.3 mm
Weight	250 grams
Operating temperature range	-10°C to + 40°C
Shock	10 g, half sine shape, 6-10 ms duration
Vibration	3 g, sinusoidal vibration sweeps 5- 150 Hz
Compliance CE/UL	CE compliant

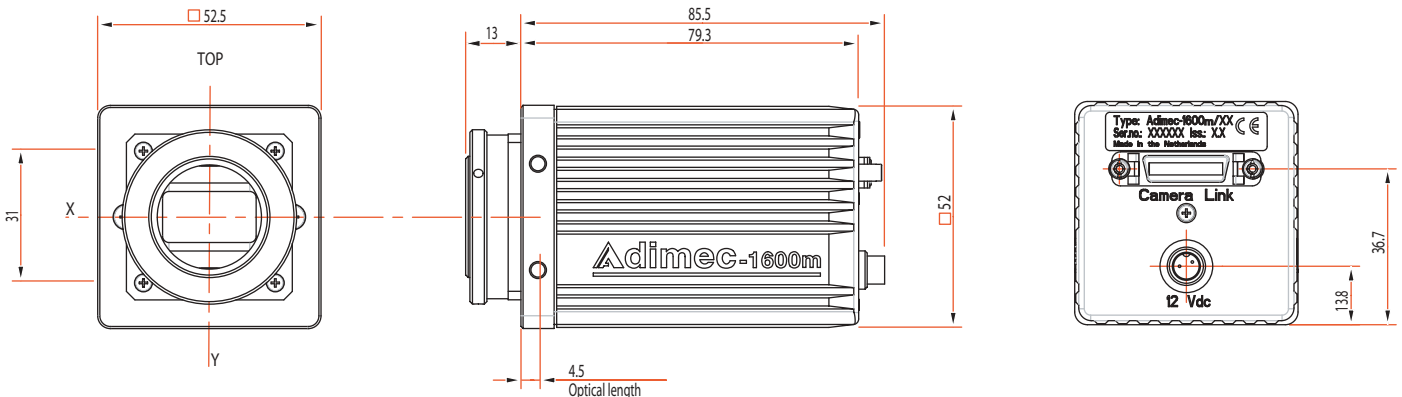

ADIMEC:

Adimec is a leading worldwide supplier of high performance, innovative, and reliable camera products for use in:

- Machine Vision
- Medical Imaging
- Military Targeting and Observation

Adimec's mission is to serve leading OEM's around the world who view quality and reliability as essential to their success.

Contact us today to find out why top corporations rely on Adimec.

Visit our website: www.adimec.com